

# **Operating Instructions**

## **Machine-Side Hopper Loader SSE Series**

Sterling Material Processing  
5200 West Clinton Ave.  
Milwaukee, WI 53223

Telephone: (414) 354-0970  
Fax: (414) 354-6421

[www.sterlco.com](http://www.sterlco.com)

Technical service:  
Service department  
Telephone: (800) 423-3183

Edition: 03/04  
Bulletin #: SM4-615.2

These operating instructions are for\*:  
(\* please fill in personally)

Serial number:  
Year of manufacture:  
Date of Delivery:  
Number of delivery:  
Date of commissioning:  
Location:  
Group of machines:

Sterling Material Processing retains all rights to change the information in these operating instructions at any time without notice.

We assume no liability for any errors or direct or indirect damage resulting in context with these operating instructions.

Copying, translation or publication in any form except for personal use of purchaser requires approval from Sterling Material Processing.

All rights reserved.



## Please note that our address and phone information has changed. Please reference this page for updated contact information.



These manuals are obsolete and are provided only for their technical information, data and capacities. Portions of these manuals detailing procedures or precautions in the operation, inspection, maintenance and repair of the products may be inadequate, inaccurate, and/or incomplete and shouldn't be relied upon. Please contact the ACS Group for more current information about these manuals and their warnings and precautions.

### Parts and Service Department

The ACS Customer Service Group will provide your company with genuine OEM quality parts manufactured to engineering design specifications, which will maximize your equipment's performance and efficiency. To assist in expediting your phone or fax order, please have the model and serial number of your unit when you contact us. A customer replacement parts list is included in this manual for your convenience. ACS welcomes inquiries on all your parts needs and is dedicated to providing excellent customer service.

#### For immediate assistance, please contact:

- North, Central and South America, 8am – 5pm CST +1 (800) 483-3919 for drying, conveying, heating and cooling and automation. For size reduction: +1 (800) 229-2919.  
North America, emergencies after 5pm CST (847) 439-5855  
**North America email: [acsuscanadacustserv@corpemail.com](mailto:acsuscanadacustserv@corpemail.com)**
- Mexico, Central & South America  
**Email: [acslatinamericacustserv@corpemail.com](mailto:acslatinamericacustserv@corpemail.com)**
- Europe, Middle East & Africa +48 22 390 9720  
**Email: [acseuropecustserv@corpemail.com](mailto:acseuropecustserv@corpemail.com)**
- India +91 21 35329112  
**Email: [acsindiacustserv@corpemail.com](mailto:acsindiacustserv@corpemail.com)**
- Asia/Australia +86 512 8717 1919  
**Email: [acsasiacustserv@corpemail.com](mailto:acsasiacustserv@corpemail.com)**

### Sales and Contracting Department

Our products are sold by a worldwide network of independent sales representatives. Contact our Sales Department for the name of the sales representative nearest you.

Let us install your system. The Contract Department offers any or all of these services: project planning; system packages including drawings; equipment, labor, and construction materials; and union or non-union installations.

#### For assistance with your sales or system contracting needs please Call:

North, Central and South America +1 (262) 641-8600 or +1 (847) 273-7700 Monday–Friday, 8am–5pm CST

Europe/Middle East/Africa +48 22 390 9720

India +91 21 35329112

Asia/Australia +86 512 8717 1919

#### Facilities:

ACS offers facilities around the world to service you no matter where you are located. For more information, please visit us at [www.acscorporate.com](http://www.acscorporate.com)

United States:

#### ACS Schaumburg – Corporate Offices

1100 E. Woodfield Road  
Suite 588  
Schaumburg, IL 60173  
Phone: + 1 847 273 7700  
Fax: + 1 847 273 7804

#### ACS New Berlin – Manufacturing Facility

2900 S. 160<sup>th</sup> Street  
New Berlin, WI 53151  
Phone : +1 262 641 8600  
Fax: + 1 262 641 8653

Asia/Australia:

#### ACS Suzhou

109 Xingpu Road SIP  
Suzhou, China 215126  
Phone: + 86 8717 1919  
Fax: +86 512 8717 1916

Europe/Middle East/Africa:

#### ACS Warsaw

Ul. Działkowa 115  
02-234 Warszawa  
Phone: + 48 22 390 9720  
Fax: +48 22 390 9724

India

#### ACS India

Gat No. 191/1, Sandbhor Complex  
Mhalunge, Chakan, Tal Khed,  
Dist. Pune 410501, India  
Phone: +91 21 35329112  
Fax: + 91 20 40147576

## Table of Contents

<b>1. General instructions.....</b>	<b>1-1</b>
1.1. Warnings and symbols .....	1-2
1.2. Explanations and information .....	1-3
1.3. Legal basis .....	1-3
1.4. Fields of applications.....	1-3
1.5. Notes on usage.....	1-3
<b>2. Safety instructions .....</b>	<b>2-1</b>
2.1. For your safety.....	2-2
2.1.1. <i>General</i> .....	2-2
2.1.2. <i>Assembly</i> .....	2-3
2.1.3. <i>Operation</i> .....	2-4
2.1.4. <i>Maintenance</i> .....	2-4
2.2. For the operating safety of the equipment .....	2-5
<b>3. Transport, assembly and storage .....</b>	<b>3-1</b>
3.1. Transport and packing .....	3-2
3.2. Assembly .....	3-2
3.3. Storage .....	3-2
<b>4. Assembly instructions.....</b>	<b>4-1</b>
4.1. Unpacking.....	4-2
4.2. Installing the dump valve sensor.....	4-3
4.3. Attaching the pickup wand.....	4-4
4.4. Mounting.....	4-5
4.4.1. <i>Mounting on the processing machine</i> .....	4-6
4.4.2. <i>Mounting onto a machine hopper</i> .....	4-6
4.4.3. <i>Mounting onto mixing hoppers with lateral inlet</i> .....	4-7
4.4.4. <i>Mounting onto DT 30 dosing station</i> .....	4-7
4.5. Electrical connection .....	4-8
4.6. Compressed air connection .....	4-8
4.7. Installation of the optional proportioning valve .....	4-9
<b>5. Functional description .....</b>	<b>5-1</b>
5.1. Sequence of operation .....	5-2
5.2. Controller .....	5-2
<b>6. Operation .....</b>	<b>6-1</b>
6.1. Switching on the unit.....	6-2
6.2. Checking the flexible hose .....	6-2
6.3. Setting the conveying time.....	6-3
6.4. Setting the purge time (optional) .....	6-4
6.5. Initial operation.....	6-5
6.6. Switching off the unit.....	6-5
<b>7. Troubleshooting.....</b>	<b>7-1</b>
7.1. Alarms.....	7-2

<b>8. Maintenance</b> .....	<b>8-1</b>
8.1. Maintenance intervals.....	8-3
8.2. Servicing the loader.....	8-4
<i>Changing the sealing ring of the outlet flap</i> .....	8-4
8.2.2. <i>Adjusting the dump valve sensor</i> .....	8-5
8.2.3. <i>Cleaning the unit</i> .....	8-6
8.2.4. <i>Replacing carbon brushes at the motor</i> .....	8-8
8.3. Taking out of service, dismantling, disposal.....	8-10
8.3.1. <i>General</i> .....	8-10
8.3.2. <i>Disposal Instructions</i> .....	8-10
<b>9. Technical data</b> .....	<b>9-1</b>
<b>10. Spare parts list</b> .....	<b>10-1</b>
10.1. Parts breakdown, brush-type motor.....	10-2
10.2. Parts lists, 2-liter model.....	10-3
10.2.1. 230 V, 50 Hz.....	10-3
10.2.2. 110 V, 60 Hz.....	10-4
10.2.3. 230 V, 50 Hz with active cleaning.....	10-5
10.2.4. 110 V, 60 Hz with active cleaning.....	10-5
10.3. Parts list, 5-liter model.....	10-6
10.3.1. 230 V, 50 Hz (V66372, V66363).....	10-6
10.3.2. 110 V, 60 Hz (V66378US).....	10-7
10.3.3. 230 V, 50 Hz with active cleaning (V66364).....	10-8
10.3.4. 110 V, 60 Hz with active cleaning.....	10-8
10.4. Parts breakdown and list, 5-liter model with brushless motor.....	10-9
10.5. 230 V, 50 Hz.....	10-10
<b>11. Accessories</b> .....	<b>11-1</b>
<b>12. Electrical manual</b> .....	<b>12-1</b>

## 1. General instructions



**These instructions apply to all persons within the range of action of the equipment.**

**These operating instructions are to be used by all persons assigned activities connected with the equipment.**



## 1.1. Warnings and symbols

The following warnings and symbols are used in these operating instructions:



**This symbol indicates danger to life. Fatal or serious injury is possible if the corresponding instructions, regulations or warnings are not observed.**



**This symbol indicates that serious injury is possible if the corresponding instructions, regulations or warnings are not observed.**



**This symbol indicates that extensive damage to equipment is possible if the corresponding instructions, regulations or warnings are not observed.**



**This symbol indicates information important for becoming familiar with the equipment, i.e. technical correlations.**



**This symbol indicates that a technical term is explained at this point.**

## **1.2. Explanations and information**

Various terms are used in these operating instructions to ensure clarity. Therefore please note that the terms used in the text stand for the corresponding explanations listed below.

- Equipment: "Equipment" can mean an individual unit, a machine or an installation.
- Operating personnel: The "operating personnel" are persons operating the equipment on their own responsibility or according to instructions.
- Operator: The "operator" of the equipment (production manager, foreman, etc.) is the person responsible for all production sequences. The operator instructs the operating personnel of what is to be done.
- Operating instructions: The "operating instructions" describe the interaction of the equipment, production sequences or methods. The operating instructions must be compiled by the operator of the equipment.
- Equipment foreman: When several operating personnel work on one machine, the "equipment foreman" coordinates the sequences. The equipment foreman must be appointed by the operator.
- Trained personnel: "Trained personnel" are persons who, due to their training, are authorized to carry out the required work.

## **1.3. Legal basis**

See "Manufacturer's Certificate" resp. "Certificate of Conformity".

## **1.4. Fields of applications**

These machine-side hopper loaders are designed for use in facilities that require independent machine conveying systems. The loaders have been developed for conveying thermoplastic granules. A typical area of application is for processing machines and drying hoppers with throughputs of up to 400 lbs./hr (180 kg/h).

## **1.5. Notes on usage**

- Experienced operators can begin directly with the chapter on "Start-up" if the unit has been properly installed.
- If the unit has not been installed yet, observe the instructions in the chapters "Transport, Assembly and Storage" and "Assembly Instructions".



## 2. Safety instructions



**These safety instructions apply to all persons within the range of action of the equipment, and should be used by all persons assigned activities connected with the equipment.**

**Please inform all persons within the range of action of the equipment of the direct and indirect hazards connected with the equipment.**

**Knowledge of the English language is prerequisite.**

**Ensure that all operating personnel are familiar with the operating instructions and the function of the equipment.**

## **2.1. For your safety**

### **2.1.1. General**

To prevent injury and/or damage to equipment, observe the following safety rules:

- Read these operating instructions carefully before operating for the first time. Contact us should questions arise.
- These operating instructions must be kept available at all times at the place of operation of the equipment.
- Please note that, for reasons of clarity, not all conceivable cases regarding operation or maintenance of the equipment can be covered in these operating instructions.
- Observe all safety instructions and warnings on the equipment.
- All work on the equipment is to be carried out by persons whose qualifications are specified in the pertaining chapters of the operating instructions.
- Wear proper working clothes while performing any work on the equipment.
- The local regulations and requirements pertaining to this equipment must be observed.
- Disconnect electrical components from the main power supply before work is carried out on these components
- Compile detailed operating instructions based on these operating instructions for the sequence of procedures to be carried out on this equipment.
- Please note that sound levels exceeding 85 db(A) may in the long term damage your health. Use appropriate ear protection to prevent hearing impairment.

### **2.1.2. Assembly**

To prevent injury and/or damage to equipment, observe the following safety rules:

- Compare the connected loads with those of the main supply.
- Use care when using lifting gear, and observe any pertaining regulations.
- Do not modify, add other equipment or change the design of the equipment without the approval of the manufacturer.
- Attachments not supplied by the manufacturer must be manufactured in accordance with safety regulation EN 294.
- Make sure all the accessories and components are properly connected in accordance with any relevant regulations.
- To prevent electrical shock, operate the device only if all its components are grounded.
- Do not allow solid particles and dust to enter to the vacuum generator.

### 2.1.3. Operation

To prevent injury and/or damage to equipment, observe the following safety rules:

- Appoint an equipment foreman to be responsible for the equipment.
- Ensure that the operating personnel are provided detailed instruction in the operation of the equipment.
- When the main switch is switched off for reasons pertaining to safety, it must be secured against unauthorized activation.
- Repair work may be carried out by trained personnel only.
- Never operate the equipment when partially dismantled.
- In case of malfunction, shut down the equipment immediately. Have malfunctions corrected immediately.
- The equipment is intended only for conveying granulated plastics and regrinds. Any other or additional use is contrary to specifications.
- This equipment is not suitable for food processing.
- The safety instructions of the connected machines must be followed.
- Explosive gases and mixtures of gas and air must not be conveyed.

### 2.1.4. Maintenance

To prevent injury and/or damage to equipment, observe the following safety rules:

- Before starting maintenance work, appoint a supervisor.
- Inform the responsible personnel before maintenance work on the system is started.
- Disconnect the equipment from main supply before starting maintenance procedures to ensure that it cannot be switched on unintentionally.
- All pipes, hoses and screwed connections should be checked regularly for leaks and damage. Any faults that arise should be corrected immediately.
- Depressurize all compressed air piping before starting maintenance work.

## **2.2. For the operating safety of the equipment**

Never change settings if the consequences are not precisely known.

Use only original manufacturer-approved spare parts.

Please observe the maintenance schedule.

Keep record of all maintenance and repair work.

Please note that electronic components may be damaged by static discharge.

Check all electrical connections for proper fit before the equipment operated for the first time and at regular intervals.

The operating temperature range is 32 to +113 °F (0 °C to +45 °C).

The recommended storage temperature range is -13 to +131 °F (-25 °C and +55 °C).

Write down all data that you have entered into the control system.

Please ensure that all plugs are correctly plugged in.

The operating instructions of the connected machines must be followed.

Operate the device only if all its components are grounded.

Never adjust sensors without exact knowledge of their function.

Please note that a compressed air supply is required for the operation of the active cleaning option.

Compressed air supply for the active cleaning option should not exceed 87 PSI (6 bar) (active cleaning option only).

Align the suction tubes correctly.

The unit should be installed in such a way that the outlet flap swings at right angles to the moving direction of the equipment.

The load-bearing capacity of the machine flange should be adhered to.

A level indicator is required when conveying from granulators.





### 3. Transport, assembly and storage



**This chapter is intended for all operating personnel of the equipment.**

**Personnel using these instructions must be instructed in the regulations for the prevention of accidents, the operating conditions and safety regulations and their implementation.**

**Ensure in each case that the operating personnel are sufficiently informed.**

**Please inform all persons within the range of action of the equipment of the direct and indirect hazards connected with the equipment.**

**Please observe all safety regulations for the operation of lifting equipment.**

### 3.1. *Transport and packing*



**Please ensure adequate carrying capacity of the lifting equipment.**

The equipment passes rigorous testing in the factory and is packed carefully to avoid transport damage.

Please check packing on delivery for transport damage.

The inlet and discharge flanges are sealed with plugs, so that no dirt can enter during transport. Plugs must be removed before assembly.

Packing materials should be disposed of according to environmental laws or reused.

Only use for transport of the equipment a suitable lifting device (e. g. a fork lift truck or a workshop crane).

Transport must be shock-proofed and free from vibrations.

### 3.2. *Assembly*



**Please ensure adequate carrying capacity of the lifting equipment.**

**Check the carrying capacity of the point of installation, particularly if installed on a platform.**

**The place selected for installation should be as free of vibrations as possible.**

**The main power switch must be freely accessible.**

**Ground the equipment against electrostatic charging.**

### 3.3. *Storage*

The control system may only be stored at temperatures from -13 to +131 °F (-25 to +55°C).

Between delivery and machine commissioning, the equipment should be stored in a dry, dust-free and vibration-free room.

## 4. Assembly instructions



**These installation instructions are intended for persons with skills in electrical and mechanical areas due to their training, experience and received instructions.**

**Personnel using these installation instructions must be instructed in the regulations for the prevention of accidents, the operating conditions and safety regulations and their implementation.**

**Ensure in each case that the personnel are sufficiently knowledgeable about the equipment.**

**The installation instructions provided in the corresponding operating instructions apply for all connected equipment.**

**Please observe all safety regulations for the operation of lifting gear.**

**All installation work must be carried out with the equipment disconnected from electrical power and compressed air supply.**



**For installation work taking place at heights of over approx. 6 feet, use only ladders or similar equipment and working platforms intended for this purpose. At greater heights, the proper equipment for protection against falling must be used.**

**Use only suitable lifting gear that is in proper working order and load suspension devices with sufficient carrying capacity. Do not stand or work under suspended loads!**

**Use only suitable workshop equipment.**



**Install the equipment so that all parts are easily accessible; this facilitates maintenance and repair work.**

### 4.1. Unpacking

The loader is insensitive to shocks and can be mounted directly onto the processing machine, on a machine hopper, a drying hopper or a dosing and blending unit.

The equipment is delivered as a complete assembly.

Use the following procedure to prepare the machine for assembly:

1. Unpack the equipment.
2. Remove the plastic stopper (A) from the material inlet nozzle.
3. Open the access door (B) and remove the adhesive tape from the dump valve.



**The controller must be freely accessible.**

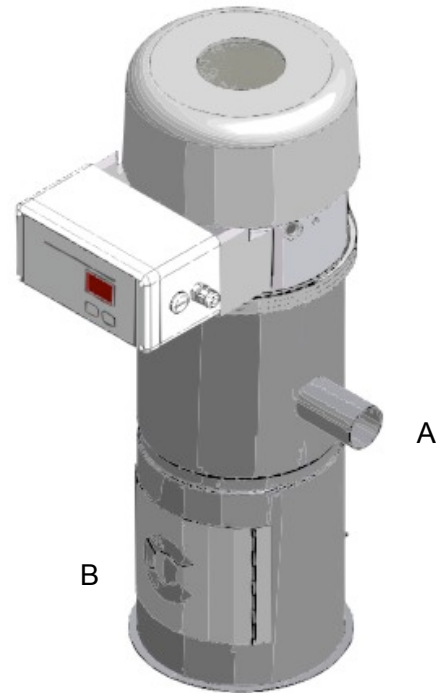

**Figure 1: 2-liter model**

#### 4.2. Installing the dump valve sensor

The controller uses a dump valve sensor (A) with a magnet (B) to determine demand. When the dump valve is closed, indicating demand, the magnet is pushed towards the sensor. The presence of the magnet near the sensor indicates demand and triggers a new conveying cycle.

When the dump valve is open, indicating that no material is needed, the magnet is pushed up and away from the sensor. If the sensor does not detect the magnet, it does not trigger a new conveying cycle.

To install the dump valve sensor, insert the appliance plug of the dump valve sensor into the connector (Figure 3) on the lower side of the controller.

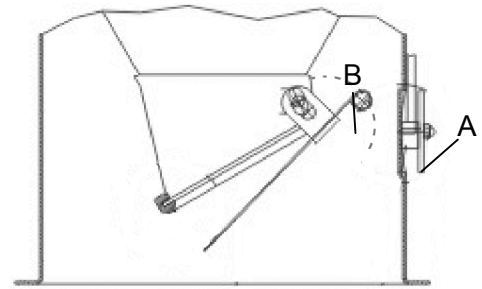

Figure 2: Dump valve and sensor

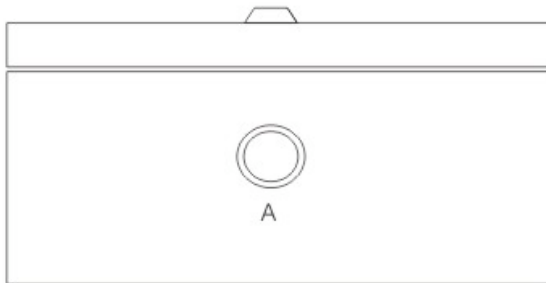

Figure 3: Lower side of the controller

### **4.3. Attaching the pickup wand**

Use the following procedure to attach the pickup wand:

1. The pickup wand must be connected to flexible hose to allow sufficient movement. The length of the hose should not exceed 10 feet (3 meters). Push the free pipe end approximately 1.5" to 2" (4-5 cm) into the hose. Use a hose clamp to secure the connection. The flex hose should not cover the aeration holes on the pickup wand.
2. Slide the flexible hose onto the material inlet. Use the hose clamps supplied to secure the flex hose.

The pickup wand needs no adjustment for most applications. Insert it into the material to be conveyed and turn the loader on. Some applications require a more defined air-to-material ratio.

The pickup wand can be angled up to approximately 45 degrees in either direction to the vertical. Additional fastening is not required.

When conveying from the bottom of storage containers (silos, surge bins, blender bins, etc.), a suction box is required.

#### 4.4. Mounting

Please check during assembly that the admissible bearing loads are not exceeded.

Mount the loader in such a way that the outlet flap swings in a right angle to the direction of machine movement.

Please check that all connecting points are tight to ensure that the conveying performance is not impaired.

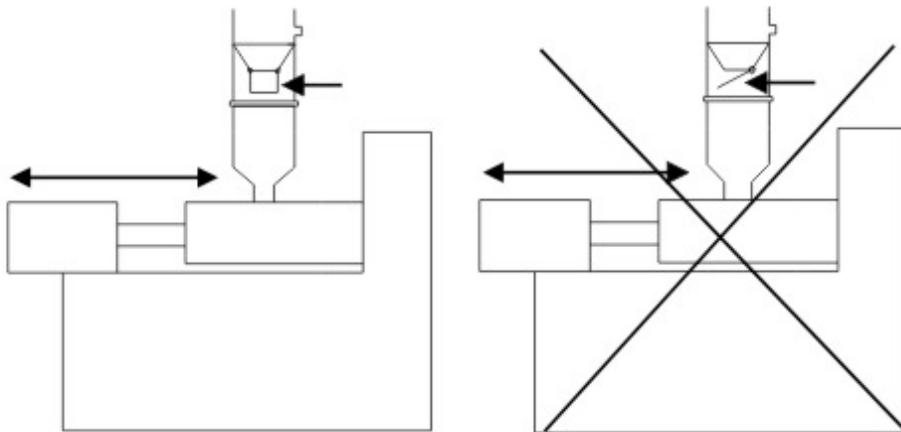

Figure 4: Mounting



#### 4.4.1. Mounting on the processing machine

A VT Series adapter is required to mount the loader on the processing machine. Two-liter models require a VT 1.0 adapter. Five-liter models require a VT 2.3/70 or VT 2.8/70 adapter. Use the following procedure to mount the loader to the processing machine:

1. Mount the VT Series adapter onto the flange of the processing machine.
2. Mount the loader onto the adapter.



Figure 5: VT Adapter



**Observe the bearing capacity of the machine flange.**

#### 4.4.2. Mounting onto a machine hopper

Two-liter models require an EF 190 welding flange for mounting onto a machine hopper. Five-liter models can be mounted to a machine hopper using either the EF 253 welding flange or the MF 253 assembly flange.

**Using the EF Series Welding Flange:**



**Please observe all safety regulations for the operation of welding equipments.**

**Always wear safety goggles.**

1. Weld the welding flange into the machine hopper lid.
2. Mount the loader onto the welding flange.



Figure 6: EF Welding Flange

**Using the MF Series Assembly Flange (Five liter models only)**

1. Mount the assembly flange into the machine hopper lid.
2. Mount the loader onto the assembly flange.



Figure 7: MF Assembly Flange

#### 4.4.3. Mounting onto mixing hoppers with lateral inlet

A VT Series adapter is required to mount the loader on a mixing hopper with a lateral inlet. Two-liter models require a VT 1.0 adapter. Five-liter models require a VT 2.3/70 or VT 2.8/70 adapter. Use the following procedure to mount the loader to the mixing hopper:

1. Mount the adapter onto the swan-neck of the mixing hopper.
2. Mount the loader onto the adapter.

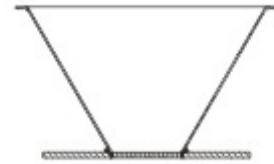

Figure 8: VT Adapter



Observe the bearing capacity of the machine flange.

#### 4.4.4. Mounting onto DT 30 dosing station

Two-liter loaders mount directly onto the DT 30 Dosing Station. Five-liter models require an AD 1/5 adapter.

##### Two Liter Models:

1. Mount the dosing hopper directly onto the dosing container of the dosing station DT 30.
2. Mount the loader onto the dosing hopper.

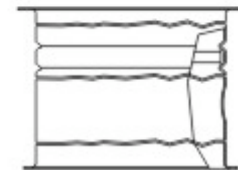

Figure 9: DT 30



Observe the bearing capacity of the machine flange.

##### Five Liter Models:

1. Mount the adapter piece directly onto the dosing container of the dosing station DT 30.
2. Mount the loader onto the adapter piece.

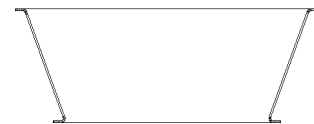

Figure 10: AD 1/5



Observe the bearing capacity of the machine flange.

## 4.5. *Electrical connection*



**The regulations of the local electrical codes must be observed.**

**Before connection to the electricity supply, ensure that the supply voltage and the power frequency are in accordance with the data on the nameplate of the machine.**

**The electrical connection may only be carried out by the manufacturer's service staff or trained personnel authorized by the manufacturer.**

**It is not permitted for other persons to undertake the electrical connection.**

**The main switch must be freely accessible.**

**Ground the equipment against electrostatic charging.**

The equipment is connected to main power supply by a standard plug.

Separate fuse protection of the wall socket is required (max. 16 A).

## 4.6. *Compressed air connection*

The hopper loader requires a clean, dry, 72-87 psi compressed air supply. A filter, regulator, and shut-off valve are recommended components of your in-plant air supply.

You may need to install an accumulator in your air supply system to enhance blowback effectiveness if your system cannot consistently meet these requirements. Make sure you use full-sized 3/8" diameter pipe or tubing when making the connection.

## 4.7. Installation of the optional proportioning valve



**Before proceeding, review the connecting diagram included with the unit.**

**For more information, refer to the manual that shipped with the proportioning valve.**

### **Connecting the proportioning valve:**

Control and power of the proportioning valve is supplied through a 4-wire control connection.

Brown	–	Positive Power	X7, L
Blue	–	Negative power	X7, N
Black	–	Line signal	X7, ZKW
Green w/ Yellow	–	Ground	X3

1. Remove the control box face, and locate the removable plug in the bottom of the box.
2. Remove the plug and feed the wire of the proportioning valve through the empty hole.
3. Tighten the lock nut inside, position the wire length for optimum use and tighten the lock nut on the outside.
4. Strip the wires so that 1/4" of wire is showing, for connection to terminal blocks.
5. Upon removal of the loader control face you will see two printed circuit boards. One board on the reverse of the control face, and the other mounted inside the control box. The ground wire will connect to the terminal block X3 on the back of the control face. The other three wires connect to terminal block X7 inside the control box, in order from left to right Brown, Blue, then Black. Please refer to the schematic in the back of the manual.

**Connecting Material Lines:**

Component 1 – connected to the intake port furthest from the air cylinder (regrind)

Component 2 – connected to the intake port closest to the air cylinder (virgin)

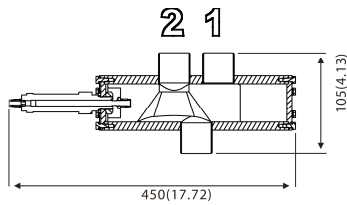

**Setting the ratio:**

When the loader motor is not running, pressing the arrow key on the valve's controller will change the percentage of component 1. This can be set from 0% to 99%

**Set the cycle switching:**

Press and hold the percentage key on the valve's controller. Then by pressing the up arrow, you will be selecting the cycle time period in increments of 5 sec.

For example, if the convey time is 60 seconds and you select a cycle time period of 10 sec. the valve will switch a total of 6 times.

## 5. Functional description



**This functional description is intended for all operating personnel of the equipment.**

**General knowledge of conveying systems is required to operate the equipment**

**Ensure in each case that the operating personnel are sufficiently knowledgeable about the equipment.**

### 5.1. Sequence of operation

The sequence of operation is as follows:

1. Plug in the machine and move the on/off switch to the “on” position
2. All LEDs on the controller blink, and the software version is displayed on the screen.
3. A 2-second blowback pulse cleans the filter. During blowback, the screen displays “A2.”
4. The motor starts, and conveying begins. The screen displays a countdown of the conveying time. Conveying time can be set for 1-99 seconds.
5. If the optional purge valve is installed, line purging begins, and the screen displays a countdown of purge time. Purge time can be set for 0-99 seconds.
6. The motor shuts off for 8 seconds while material dumps. The screen displays “L8.” The 8-second dump time is a fixed setting and is not adjustable.
7. The controller checks for demand, and if material is needed, the cycle starts over from step 3.

### 5.2. Controller

3 LEDs indicate the respective modes of operation: blowback, conveying, purging, and dumping.

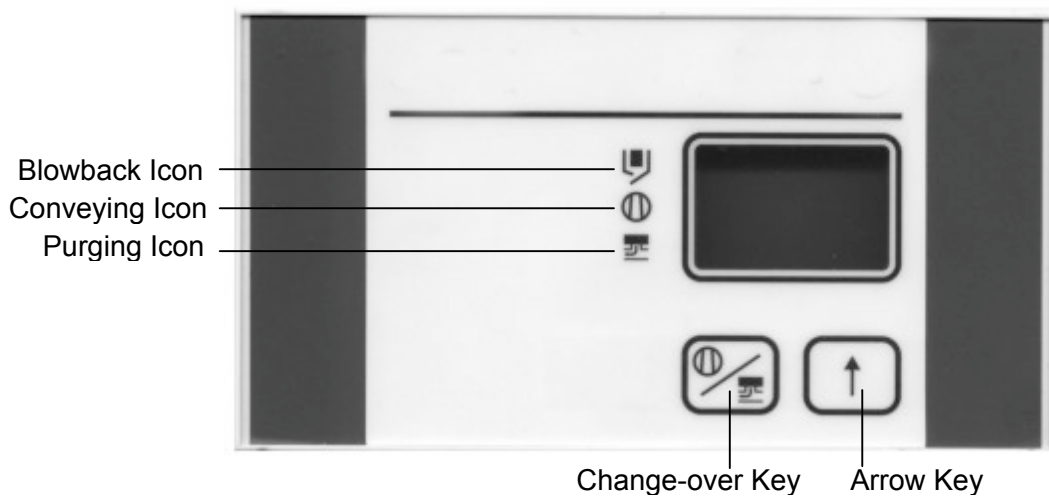
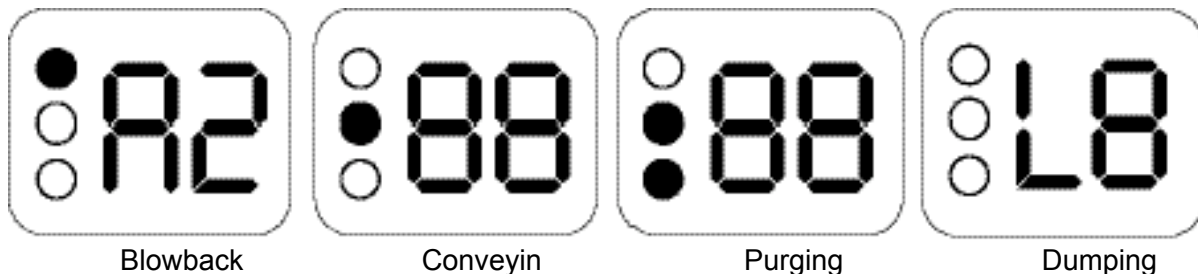

Figure 11: Controller

## 6. Operation



**This chapter is intended for operating personnel.**

**General knowledge of the operation of conveying systems is required to perform these tasks. Make sure you have read and understood the Functional Description chapter in this manual before operating the equipment.**

**Ensure that all operating personnel are sufficiently knowledgeable about the equipment.**



**Make sure the plastic stopper has been removed from the material inlet nozzle.**

**Make sure the adhesive tape has been removed from the exit flap.**



### **6.1. Switching on the unit**

Locate the power switch on the left side of the control box and switch it to the “on” position.

### **6.2. Checking the flexible hose**

Before operating the equipment, check to make sure the suction is working:

1. Remove the pickup wand from the flexible hose.
2. Cover the open end of the hose with your hand.
3. Connect the unit to the main power supply and turn the machine on.
  - a. If the motor is operating, your hand will feel the suction within few seconds.
  - b. If you don't feel the vacuum, the flexible hose is not tight.
4. Check the hose and seal any loose points you may have identified.
5. Reconnect the pickup wand.

### 6.3. Setting the conveying time



**Do not overfill the hopper loader**



**The conveying time cannot be set while the unit is in the process of conveying material.**

By correctly setting the conveying time, you can reduce vacuum motor wear, save energy, and reduce your need to maintain filters:

1. Turn on the hopper loader
2. Observe the flex hose and the material in which you buried the pickup probe. Listen to the vacuum motor and the sound that the material makes as it enters the hopper loader.
3. When the hopper loader is full, the conveying rate drops off sharply. You can observe this condition in the clear flex hose and the material container in which you buried the pickup probe. When the hopper loader is full, the vacuum motor and material sounds also change.
4. Make a note of the elapsed time from the start of conveying to the time the hopper loader is full.
5. Turn the hopper loader off
6. Disable the conveying cycle by disconnecting the dump valve sensor from the controller. With the dump valve sensor disabled, no demand will be indicated, and the conveying cycle will not start.
7. Turn the hopper loader on.
8. Use the arrow key to adjust the conveying time to slightly shorter than it takes to fill the hopper loader. For example, if the hopper is full by the 30-second point of the conveying sequence, set the conveying time to 28 seconds.



**NOTE:** To decrease the load time setting it is necessary to cycle the time setting past 99 and then to the desired setting. There is no “down” button.

9. With the new time setting entered, reconnect the dump valve sensor. Conveying should start again.



**The conveying time that was last selected appears in the display.**

**The conveying time can be set at 1 to 99 seconds.**

- If the hopper loader is overfilling, reduce the conveying time.
  - If the hopper loader is not filling to capacity, increase the conveying time.
10. Check operation to ensure proper settings. If settings are not right, repeat steps 1-9.

## 6.4. Setting the purge time (optional)

To set the purge time, press and hold the “change-over” key while using the “arrow key” to adjust the time.



**The purge time that was last selected appears in the display.**

**The purge time can be set at 1 to 99 seconds.**



**If no line clearing valve has been installed, enter “0”.**

1. Turn the hopper loader off.
2. Disable the conveying cycle by disconnecting the dump valve sensor from the controller. With the dump valve sensor disabled, no demand will be indicated, and the conveying cycle will not start.
3. Turn the hopper loader on.
4. Enter a conveying time setting. (See Section 6.3. on page 6-3.)
5. Enter a purge time. This is done by pressing (and holding) the change-over key (the bottom and center LED should be lit). Then pressing the arrow key. The purge time on the display will increase.
6. Reconnect the dump valve sensor. Conveying should start.
7. Verify both the load time and purge time settings. This can be done by observing the conveying cycle. When the loader motor starts, it will convey material for the time entered. After this time expires, the motor stays on and the line clearing valve is activated. At this time, the conveying line will be “purged” clean of material. When the settings are correct, the load time is just long enough to pull the desired amount of material into the conveying line and the purge time is just long enough to clean out the line. Once both of these functions are complete, the material level in the hopper should be at the material inlet level, but not above. If this is not the case readjust the settings by repeating steps 1-7.

**NOTE:** To decrease the load time and purge settings, it is necessary to cycle the time setting past 99 and then to the desired setting. There is no “down” button.

8. Once the settings are optimized, the loader is ready for operation.

### **6.5. Initial operation**

Metal shavings may be inside the pipe from cutting down pipes into lengths. These are pulled during the first conveying process and collected in the separator.



**This material should not be used again.**

### **6.6. Switching off the unit**

Locate the power switch on the left side of the control box and switch it to the “off” position.



## 7. Troubleshooting



**This chapter is intended for the operating personnel of the equipment.**

**General knowledge of the operation of conveying systems is required to perform these tasks.**

**Make sure you have read and understood the “Start-up” section of this manual before proceeding.**

**Ensure that the operating personnel are sufficiently knowledgeable about the equipment.**

## 7.1. Alarms

An alarm will be triggered if there is no material to convey or if the loader overheats.



**An “E” appears in the display and an error number.**

**And alarm will sound.**



**Do not restart operation until the malfunction has been corrected.**

The following error messages can be displayed:

### “E1”

The alarm message “E1” is displayed when no material has been conveyed during 3 consecutive conveying cycles.

- Check that sufficient material is being conveyed.
- Check that the flap switch is set correctly.

As supplied, this feature is disabled. To enable it:

1. Turn the loader off and remove power.
2. Remove the cover from the control.
3. Remove the two wires that are connected to terminals X9 and X6
4. Replace the cover and turn the loader on.

### “E2”

If the control system becomes too hot during operation (>158°F, 70°C) the “E2” alarm message is displayed and the unit is switched off.

- Allow the system to cool before restarting.



**When the malfunction has been corrected, turn the power off and then on again to restart.**

## 8. Maintenance



**This chapter is intended for persons with skills in electrical and mechanical areas due to their training, experience and received instructions.**

**Personnel using the instructions in this chapter must be instructed of the regulations for the prevention of accidents, the operating conditions and safety regulations and their implementation.**

**Ensure in each case that the personnel are sufficiently knowledgeable about the equipment.**

**For maintenance work taking place at heights of over approx. 6 feet, use only ladders or similar equipment and working platforms intended for this purpose. At greater heights, the proper equipment for protection against falling must be worn.**

**Use only suitable lifting gear that is in proper working order and load suspension devices with sufficient carrying capacity. Do not stand or work under suspended loads!**

**Ensure that the electric motors/switch cabinets are sufficiently protected against moisture.**

**Use only suitable workshop equipment.**

**Before starting maintenance work, appoint a supervisor.**

**Inform the responsible personnel before maintenance work on the system is started.**

**Never operate the equipment when partially dismantled.**

**All maintenance and repair work not described in this chapter may only be carried out by the manufacturer's service personnel or authorized personnel (appointed by the manufacturer).**



**Disconnect the equipment from main power supply before starting maintenance procedures to ensure that it cannot be switched on unintentionally.**

**Depressurize all system sections of the equipment before carrying out any repair work.**





**Please observe the maintenance intervals.**

**Before starting maintenance work, clean the equipment of oil, fuel or lubricants.**

**Ensure that materials and incidentals required for operation as well as spare parts are disposed of properly and in an environmentally sound manner.**

**Use only original Sterling spare parts.**

**Keep record of all maintenance and repair procedures.**

## 8.1. Maintenance intervals

Daily:	Check that warning labels on the equipment are clear and readable
	Clean the sieve or filter
	Use compressed air to blow through the sieve or filter (according to the accumulation of dust)
Monthly:	Check function of the power cord and plug
Every 6 months:	Check all electrical and mechanical connections for tight fit
	Check setting of the level sensor (if present, optional)
	Replace the sieve or filter (according to the accumulation of dust)
Annually:	Replace outlet valve sealing.
	Adjust valve switch
After 1000 operating hours:	Replace carbon brushes (n/a on BL models.)



**The given maintenance intervals are average values.**

**Check whether in your individual case the maintenance intervals must be shortened.**

## 8.2. Servicing the loader



Disconnect the unit from main power supply by unplugging it.

Depressurize all system sections of the equipment (only units with active cleaning).

### 8.2.1. Changing the sealing ring of the outlet flap

1. Open the toggle fasteners (A) and the access door (B) of the hopper loader.
2. Draw the old sealing ring (C) off the nozzle of the material outlet.
3. Install the new sealing ring (C).

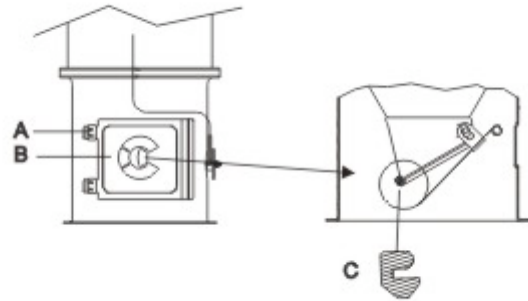

Figure 12: Installation sealing ring



**Make sure the new sealing ring (C) is installed properly. Do not install the sealing ring upside-down.**

4. Close the access door (B) and the toggle fasteners (A).



Order number sealing ring “material outlet”:

2-liter model: ID 29258

5-liter model: ID 23098

### 8.2.2. Adjusting the dump valve sensor

1. Stop the conveying cycle by disconnecting the dump valve sensor from the controller. With the dump valve sensor disabled, no demand will be indicated, and conveying will stop.
2. Connect an ohmmeter to PINS 2 and 3 of the dump valve sensor.
3. Release the nuts (A) of the dump valve sensor (B) until the support can be displaced.
4. Open the dump valve (C) so far that the front tip of the outlet flap is approx. 1.2" (30 mm) away from the sealing surface.
5. Displace the dump valve sensor (B) until the contact of the magnet switch is closed.
6. Tighten the nuts (A) of the dump valve sensor.
7. Check the adjustment: In case of free hanging dump valve (empty hopper loader) the contact of the magnet switch must be closed.
8. If the dump valve sensor cannot be properly adjusted, replace the dump valve and magnet or the sensor.

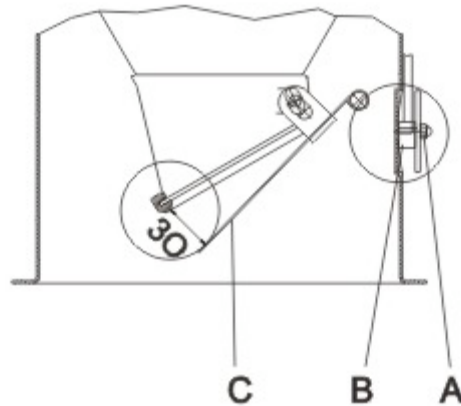

Figure 13: Dump Valve



#### Order numbers

**Sensor with plug:**

**2-liter model: ID 29570**

**5-liter model: ID 28839**

**Dump valve with magnet:**

**2-liter model: ID 28647**

**5-liter model: ID 23093**

### 8.2.3. Cleaning the unit

1. Open the toggle fastener on the tension ring.
2. Tilt the turbine head upwards.
3. Remove the filter.
4. Clean the filter by means of compressed-air.
5. Clean the hopper loader by means of a vacuum cleaner.
6. Mount the filter. Pay attention for proper fit.
7. Mount the turbine head.
8. Mount the tension ring and close the toggle fastener.



**Order number**

**filter with sealing:**

**2-liter model: ID 37755**

**5-liter model: ID 34179**

**Cleaning the filter cloth:**

1. Open the toggle fasteners (A) and the access door (B) of the hopper loader.
2. Check the filter cloth (C) and the wire cloth (D) for material residue. Clean the filter by means of compressed air.
3. Close the access door (B) and the toggle fasteners (A) on the access door of the hopper loader.

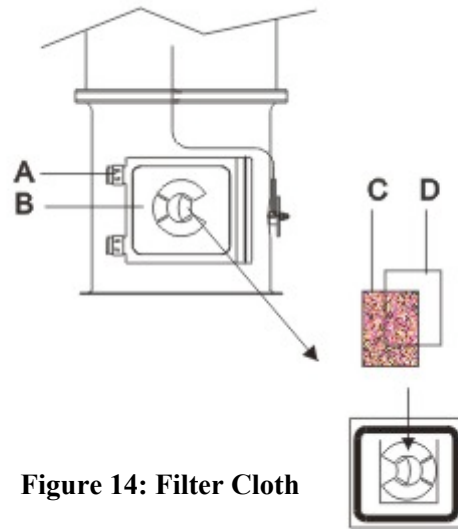

**Figure 14: Filter Cloth**



**Order numbers**

**Filter cloth: ID 28626**

**Wire cloth: ID 23091**

### 8.2.4. Replacing carbon brushes at the motor

The carbon brushes in the motor must be replaced after approximately 1000 hours of operation. The brushes can be replaced twice before the entire motor has to be replaced. "BL" model loaders feature brushless motors, and do not require this procedure.



**This work must be carried out by qualified personnel only.**

**Disconnect the unit from main power supply before working on the controller.**

**Remove compressed air and depressurize unit prior to disassembly.**

#### Disassemble the unit:

1. Remove the screws (A) at the lid.
2. Remove the lid (B).
3. Remove the latch carefully from the brush holder (C).
4. Remove the cover (D).
5. Loosen the brush holder lock.
6. Pull out the brush holder.

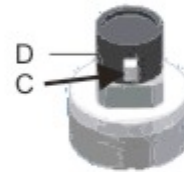

#### Installation:

1. Push the latch with the connecting line onto the new brush holder.
2. Mount the brush holder.
3. Please be careful with the latch connecting line.
4. Mount the cover.
5. Mount the lid.
6. Mount the screws at the lid.
7. Install the unit.

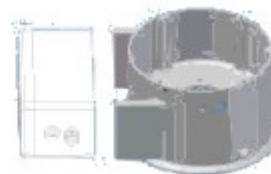

**Figure 15: Replacing the carbon brushes**



**Verify that no cables are pinched or cut.**

**Carbon brushes can be replaced twice.**

**After that the turbine has to be completely replaced.**



**Order numbers**

**Turbine (230 V, 1200 W): ID 83380**

**Carbon brushes (switching off): ID 85628**

**Turbine (230 V, 800 W): ID 85629**

**Carbon brushes (switching off): ID 85628**

**Turbine (110 V, 800 W): ID 85844**

**Carbon brushes (switching off): ID 84716**



### **8.3. Taking out of service, dismantling, disposal**



**Only skilled personnel qualified for this work may dismantle the individual product modules.**

**Parts that are under mechanical stress should be disassembled with utmost care to avoid the energy trapped in these parts from unleashing and causing injury.**

#### **8.3.1. General**

To dispose of the products, you should take the following action:

- Remove and destroy the nameplate with the CE sign.
- Completely disassemble the product and dispose of the various components or recycle them.

#### **8.3.2. Disposal Instructions**

- All components must be pressureless prior to disassembly.
- Oil, grease and other fluids have to be disposed of separately in accordance with local regulations.
- Bright steel parts are to be treated as steel scrap.
- Depending on local disposal regulations, painted steel parts may have to be shotblasted before they can be disposed of as steel scrap. Shotblast shall be disposed of separately.
- Galvanized steel parts must be disposed of separately, according to local regulations.
- Stainless steel parts are to be disposed of as stainless steel scrap.
- Aluminum parts, such as manhole components, come under aluminum scrap.
- Sealing materials have to be separately disposed of.
- Electronic components must be disposed of separately, according to local regulations.

## 9. Technical data



**These instructions apply to all persons within the range of action of the equipment.**

**These operating instructions are to be used by all persons assigned activities connected with the equipment.**

**Standard Features:**

Integrated control with:

- LED-display
- indication of the respective modes of operation
- adjustable conveying time
- adjustable line clearing time

Integrated vacuum pump

Integrated filter with automatic cleaning

Parts coming in contact with material are made of stainless steel

Simple mounting to dosing and blending units due to compact and weight saving design

Alarm output

Automatic shut-down with lack of material

Display of error codes

**Optional Features**

- Material purge valve output with adjustable line purging time.
- Two component valve output
- Granulator level sensor input
- Extension modules

**Specifications:**

	<b>2 liter model</b>	<b>5 liter model</b>	<b>5 liter model: brushless motor</b>
<b>Loader Capacity</b>	0.088 cu. ft. (2.5 l)	0.17 cu. ft. (5 l)	0.17 cu. ft. (5 l)
<b>Conveying Capacity</b>	440 lbs./hr (200 kg/hr)	770 lbs./hr (350 kg/hr)	1090 lbs./hr (500 kg/hr)
<b>Connected load</b>	230 V, AC, N, PE 50/60 Hz, 0.8 kW  110 V, AC, N, 60 Hz	230 V, AC, N, PE, 50/60 Hz, 1.2 kW	230 V, AC, N, PE, 50/60 Hz, 0.12 kW
<b>Noise Level (max)</b>	80 dbA	78 dbA	82 dbA
<b>Weight</b>	22 lbs. (20 kg)	33 lbs. (15 kg)	35 lbs. (16 kg)
<b>Air Consumption</b>	0.35 cfm at 87 PSI (10 lpm at 6 bar)	0.35 cfm at 87 PSI (10 lpm at 6 bar)	0.35 cfm at 87 PSI (10 lpm at 6 bar)

Dimension Sheet

Two-liter model:

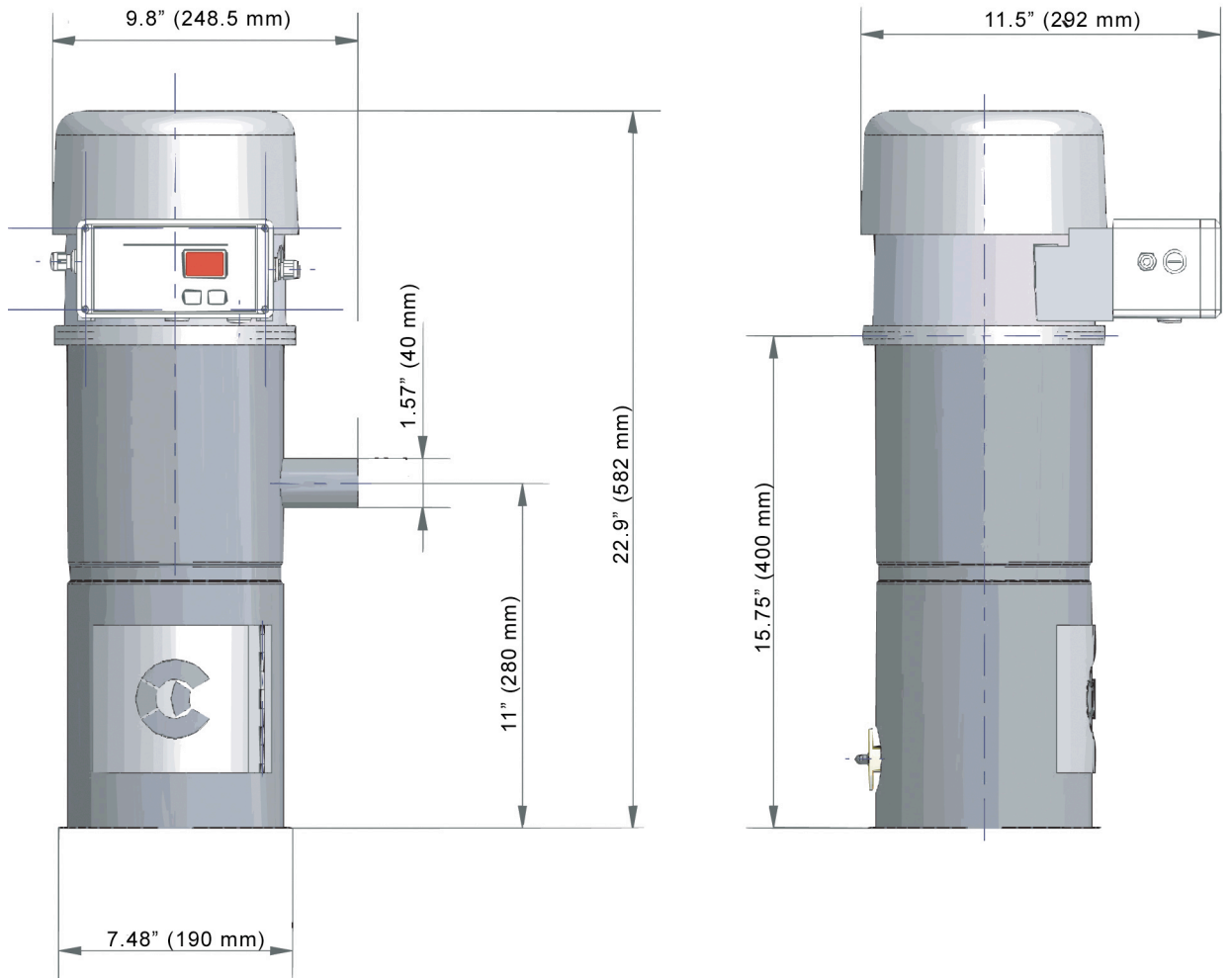

5-liter model:

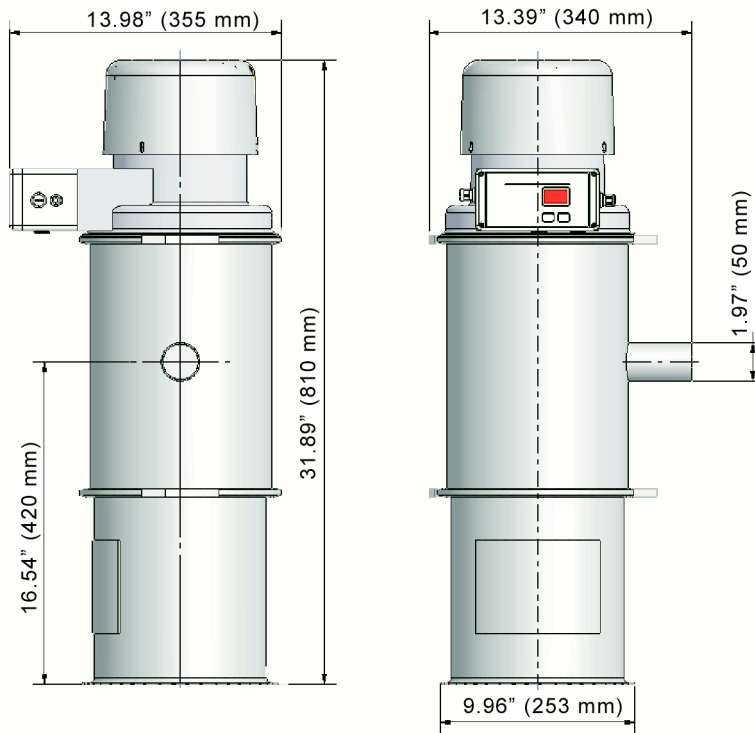

5-liter brushless model:

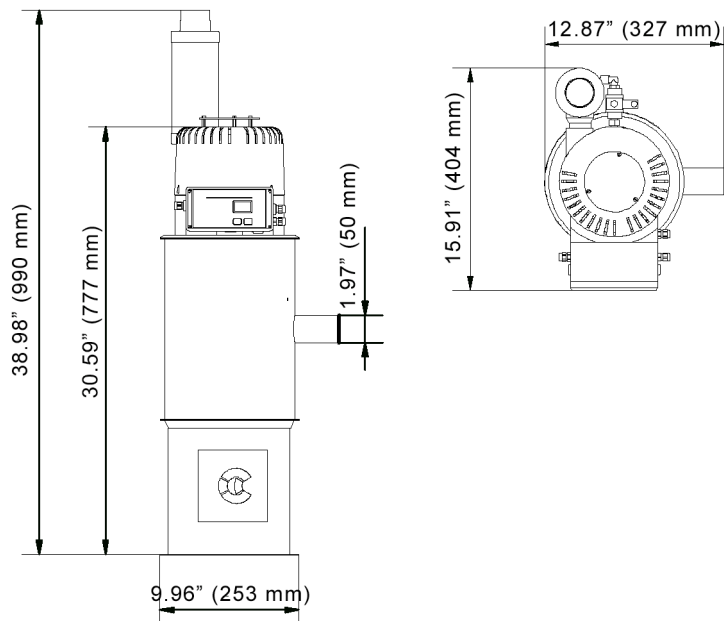

## 10. Spare parts list



**This spare parts list is intended to be used only by trained personnel.**

**Other persons are not permitted to modify or repair the equipment.**



**Wear Code:**

**A = Wearing part, wears quickly**

**B = Wearing part**

**C = Spare part, reorder every year**

**D = Spare part, reorder every 2 years**

**E = Spare part, rarely reordered**

### 10.1. Parts breakdown, brush-type motor

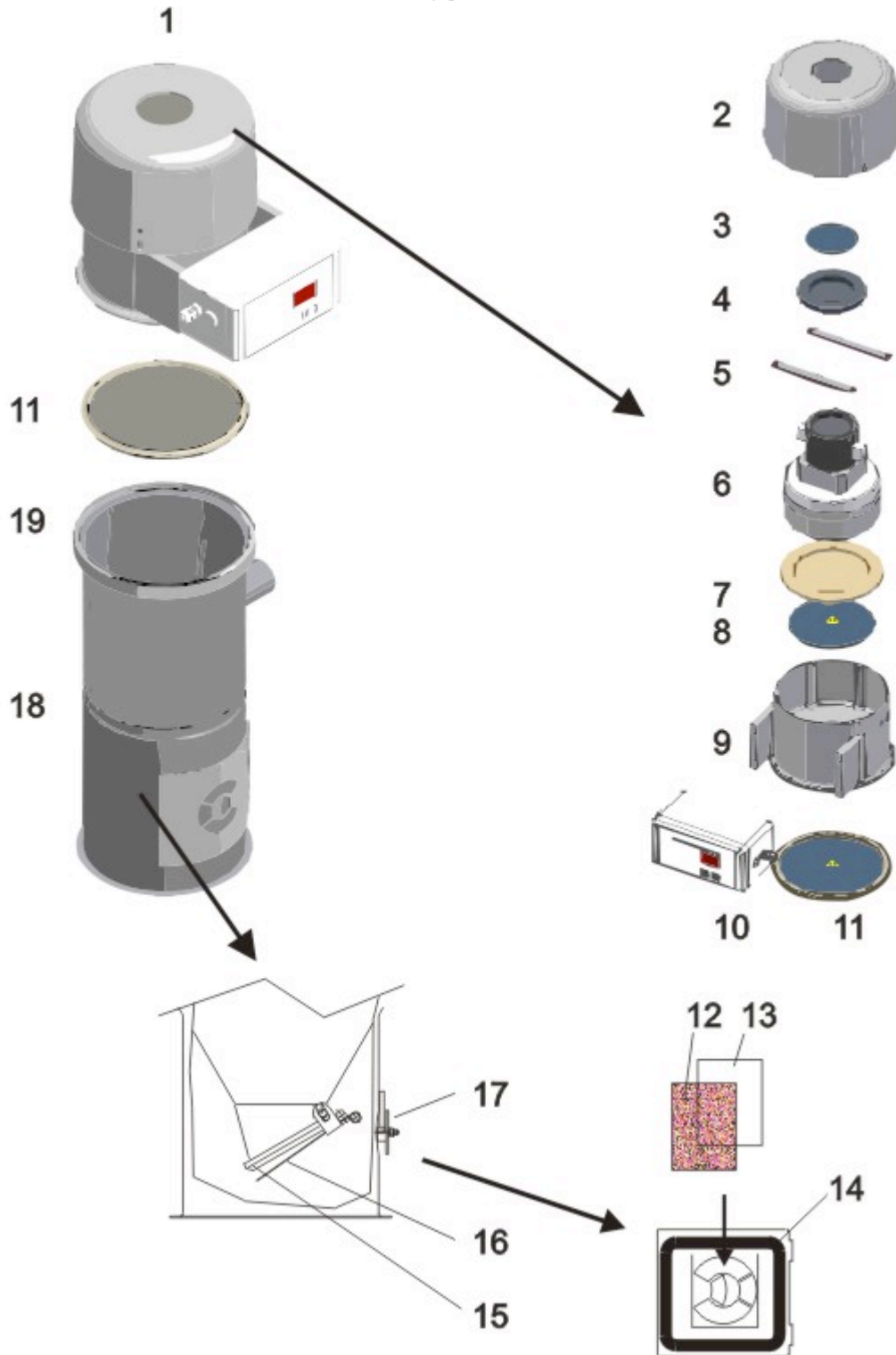

## 10.2. Parts lists, 2-liter model

### 10.2.1. 230 V, 50 Hz

Pos.	Order no.	Designation	Wear Code
1	37767	Turbine head complete, with turbine and controller	
2	37765	Covering cap	
3	18491	Sieve	
4	34197	Isolation	
5	37768	Support	
6	85629	Turbine (800 W)	D
	85628	Carbon brushes (switching off)	B
7	24679	Isolation	
8	26384	Filter round	
9	37764	Turbine lower part	
	98194	Cable bushing	
10	82277	Controller "ECO"	
	83098	High comfort control	
11	35014	Sieve with sealing ring	A
12	28626	Filter cloth	C
13	23091	Wire cloth	C
14	28625	Sealing	C
15	29258	Sealing ring	A
16	28647	Outlet flap with magnet	
17	28839	Flap switch with plug	C
	26462	Covering	C
18	37761	Separator	
19	82566	Tension ring with sealing ring	B



**10.2.2. 110 V, 60 Hz**

<b>Pos.</b>	<b>Order no.</b>	<b>Designation</b>	<b>Wear Code</b>
1	37777	Turbine head complete, with turbine and controller	
2	37765	Covering cap	
3	18491	Sieve	
4	34197	Isolation	
5	37768	Support	
6	85844	Turbine (800 W)	D
	84716	Carbon brushes (switching off)	B
7	24679	Isolation	
8	26384	Filter round	
9	37764	Turbine lower part	
	98194	Cable bushing	
10	83097	High comfort control	
11	35014	Sieve with sealing ring	A
12	28626	Filter cloth	C
13	23091	Wire cloth	C
14	28625	Sealing	C
15	29258	Sealing ring	A
16	28647	Outlet flap with magnet	
17	28839	Flap switch with plug	C
	26462	Covering	C
18	37761	Separator	
19	85481	Tension ring with sealing ring	B

**10.2.3. 230 V, 50 Hz with active cleaning**

Pos.	Order no.	Designation	Wear Code
1	37755	Filter with sealing	A
2	37222	Basket	
3	82593	Solenoid valve	B
4	97745	Bush	D
5	37800	Breather tube	D

**10.2.4. 110 V, 60 Hz with active cleaning**

Pos.	Order no.	Designation	Wear Code
1	37755	Filter with sealing	A
2	37222	Basket	
3	82592	Solenoid valve	B
4	97745	Bush	D
5	37800	Breather tube	D

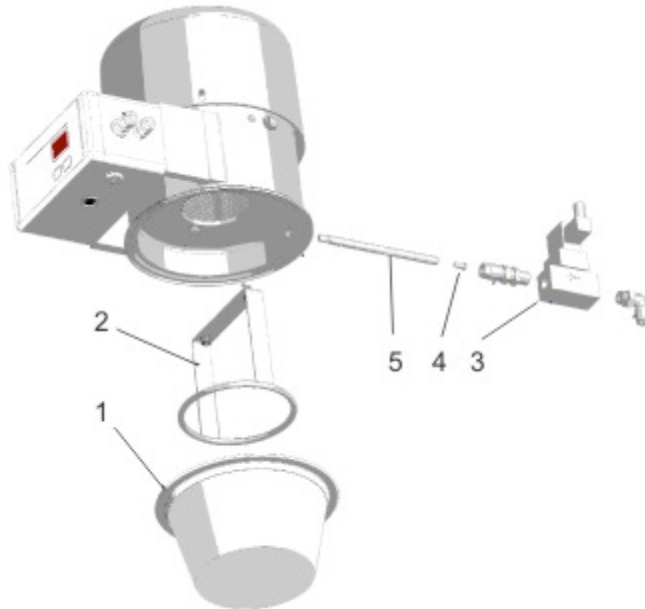

**10.3. Parts list, 5-liter model****10.3.1. 230 V, 50 Hz (V66372, V66363)**

<b>Pos.</b>	<b>Order no.</b>	<b>Designation</b>	<b>Wear Code</b>
1	38242	Turbine head complete, with turbine and controller	
2	37765	Covering cap	
3	18491	Sieve	
4	34197	Isolation	
5	37768	Support	
6	83380	Turbine (1200 W)	D
	85628	Carbon brushes (switching off)	B
7	24679	Isolation	
8	26384	Filter round	
9	37783	Turbine lower part	
	98194	Cable bushing	
10	83098	High Comfort Controller	
	82277	Controller "ECO"	
11	34193	Sieve with sealing ring	A
12	28626	Filter cloth	C
13	23091	Wire cloth	C
14	28625	Sealing	C
15	23098	Sealing ring	A
16	23093	Outlet flap with magnet	
17	28839	Flap switch with plug	C
	26462	Covering	C
18	26455	Separator, lower part	
19	82588	Tension ring with sealing ring	B
20	38243	Separator, upper part	

**10.3.2. 110 V, 60 Hz (V66378US)**

<b>Pos.</b>	<b>Order no.</b>	<b>Designation</b>	<b>Wear Code</b>
1	S39361	Turbine head complete, with turbine and controller	
2	37765	Covering cap	
3	18491	Sieve	
4	34197	Isolation	
5	37768	Support	
6	82559	Turbine (1200 W)	D
	82552	Carbon brushes (switching off)	B
7	24679	Isolation	
8	26384	Filter round	
9	37783	Turbine lower part	
	98194	Cable bushing	
10	83097	Controller	
11	34193	Sieve with sealing ring	A
12	28626	Filter cloth	C
13	23091	Wire cloth	C
14	28625	Sealing	C
15	23098	Sealing ring	A
16	23093	Outlet flap with magnet	
17	28839	Flap switch with plug	C
	26462	Covering	C
18	26455	Separator, lower part	
19	85481	Tension ring with sealing ring	B
20	38243	Separator, upper part	

**10.3.3. 230 V, 50 Hz with active cleaning (V66364)**

Pos.	Order no.	Designation	Wear Code
1	34179	Filter with sealing	A
2	37222	Basket	
3	82593	Solenoid valve	B

**10.3.4. 110 V, 60 Hz with active cleaning**

Pos.	Order no.	Designation	Wear Code
1	34179	Filter with sealing	A
2	37222	Basket	
3	82592	Solenoid valve	B

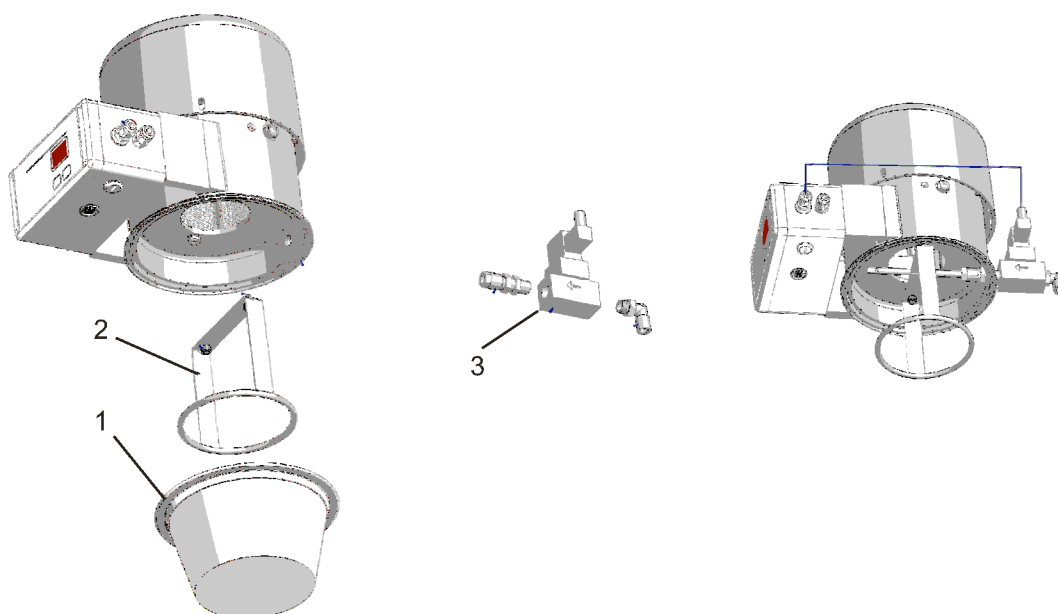

**10.4. Parts breakdown and list, 5-liter model with brushless motor**

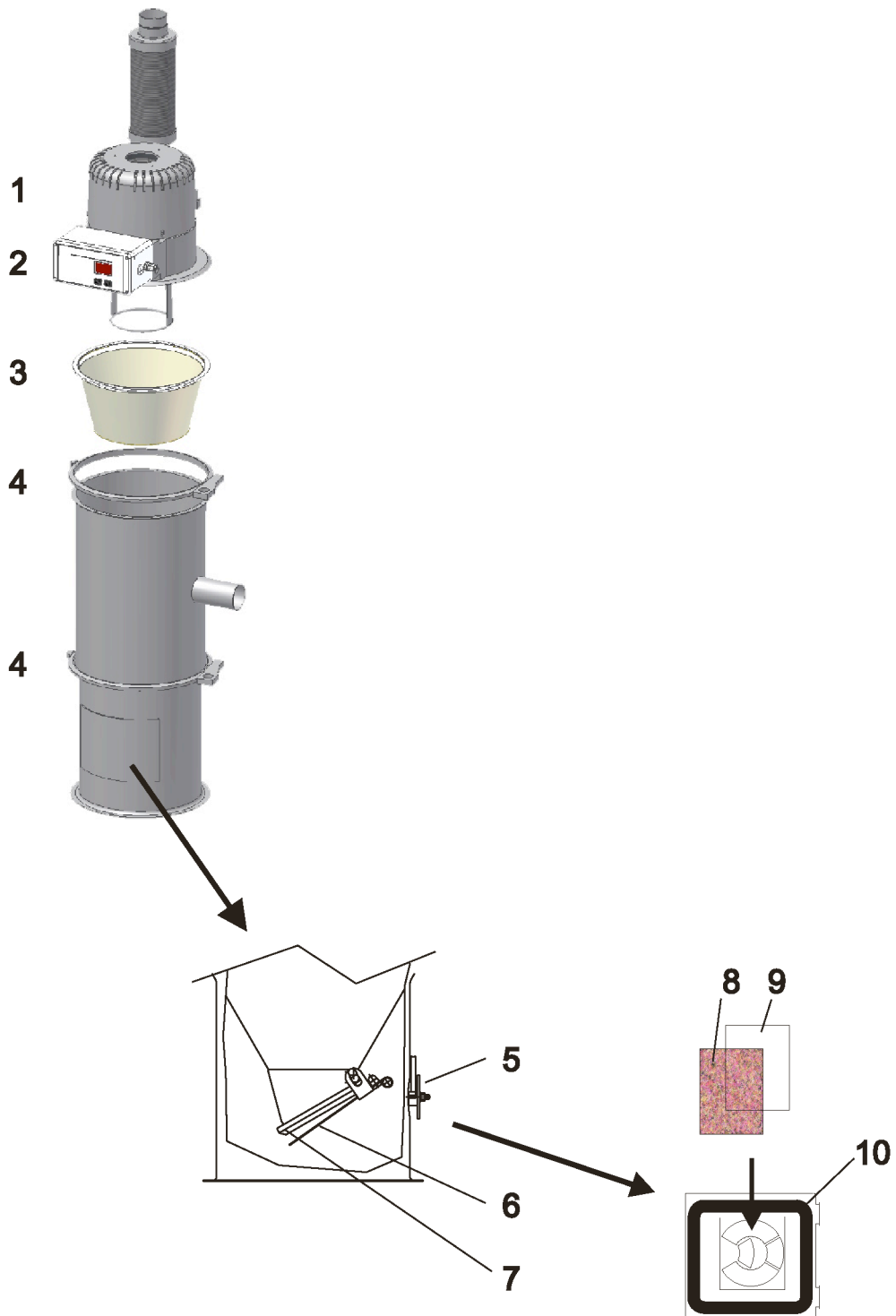

**10.5. 230 V, 50 Hz**

<b>Pos.</b>	<b>Order no.</b>	<b>Designation</b>	<b>Wear Code</b>
1	S38217	Turbine lid with turbine, complete	
	82995	Turbine 119 154-01	
	83375	Solenoid valve	
	84914	Pneumatic hose	
2	83098	Controller	
3	34179	Filter	B
4	28420	Sealing ring	C
8	5533	Tension ring	
	26451	Lock	
5	28839	Flap switch with plug	
6	23093	Outlet flap with magnet	
	85477	Nut	
	85471	Screw	
	93358	Disc	
7	23098	Sealing ring	B
8	28626	Filter cloth	D
9	23091	Wire cloth	E
10	28625	Sealing	D

## 11. Accessories

-----  
-----  
-----





## 12. Electrical manual

This electrical manual is intended to be used only by the manufacturer's service personnel and trained personnel authorized by the manufacturer.

Other persons are not permitted to modify or repair the equipment.

Terminals:

X2 = Power supply

X4 = Blower

X5 = Cleaning

X6 = Clearing

X9 = Alarm

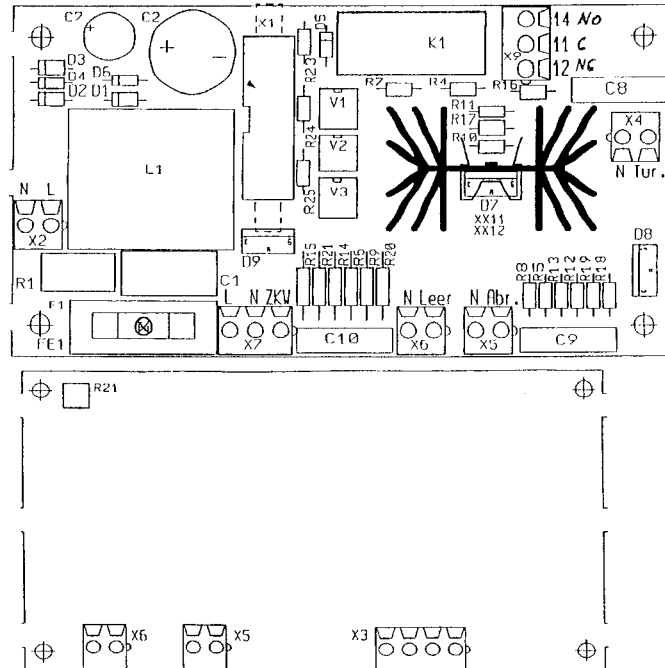

X3 = PE

X5 = Flap switch

X6 = acknowledgement key







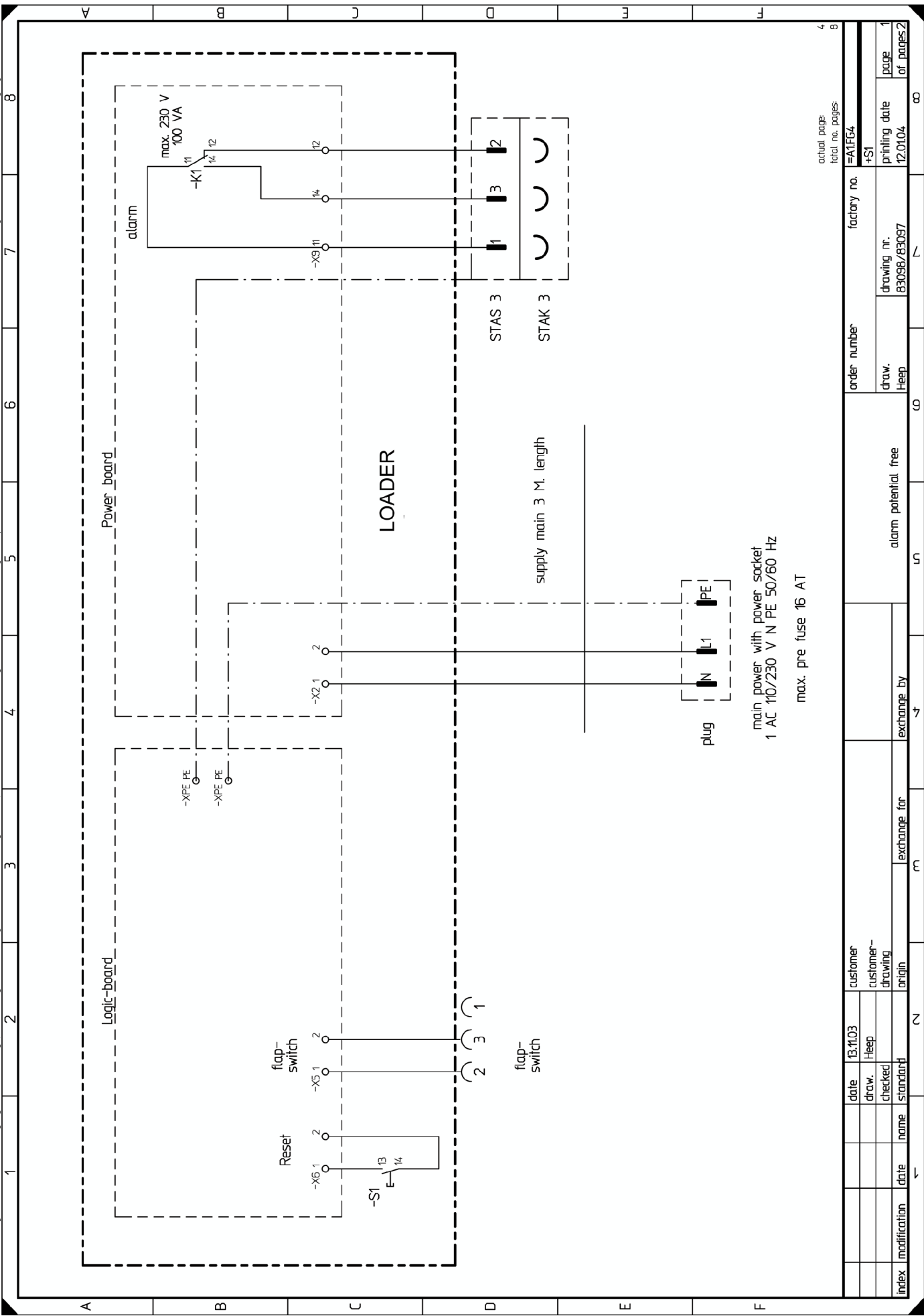

actual page	4
total no. pages	9

factory no.	=M1F64
order number	+S1

drawing nr.	83098/83097
drawing nr.	12.01.04

alarm potential free	
exchange by	

customer	customer
draw. Heep	draw. Heep
checked	checked
standard	standard

date	18.11.03
name	
date	

exchange for	
origin	

index	
modification	

exchange by	
alarm potential free	
draw. Heep	
exchange by	



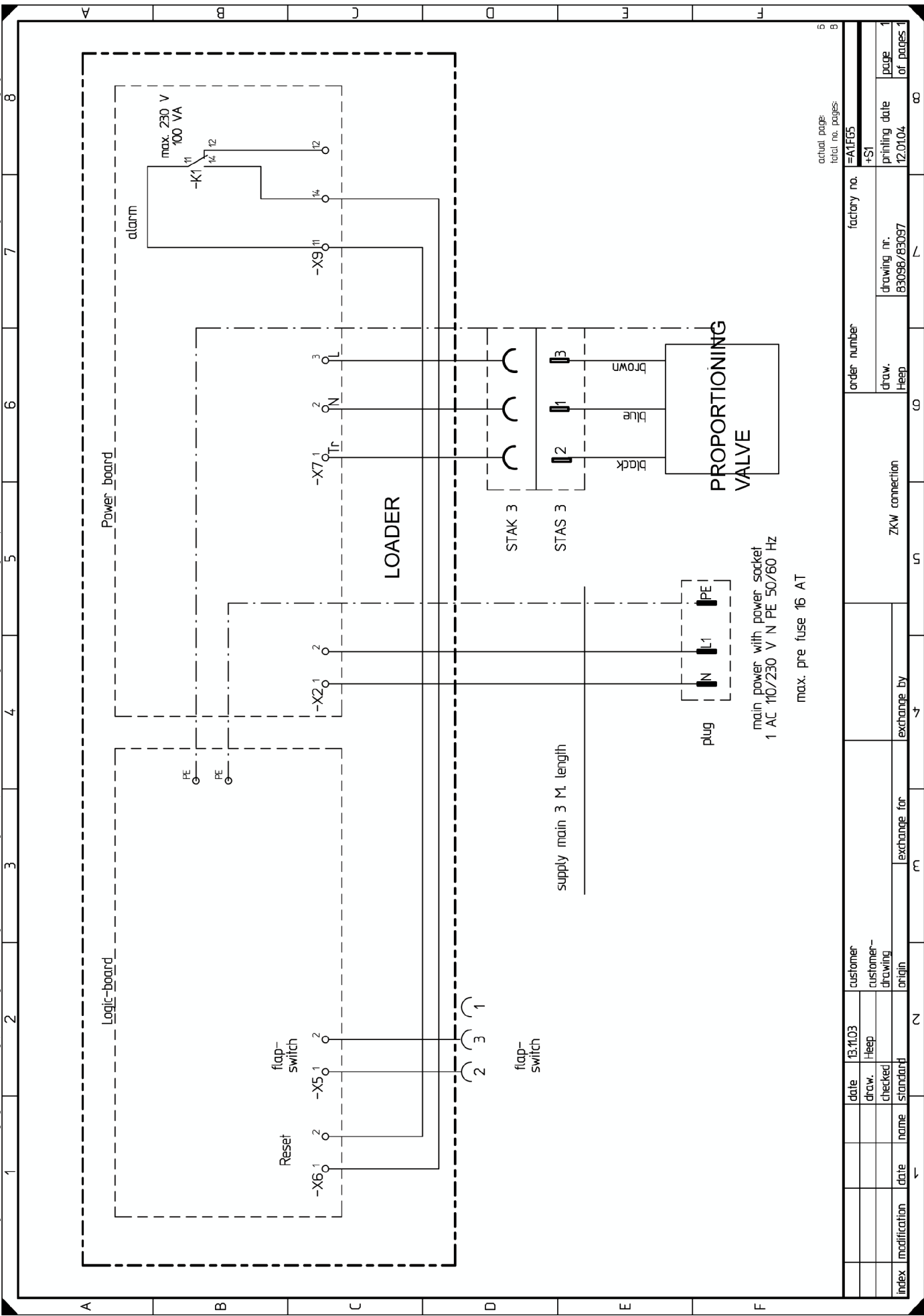









## Quick Start Guide

### Turning on the loader:

- Locate the power switch on the left side of the control box and move to the 'ON' position.

### Setting the loader convey time:

- It is only possible to set the convey time when the unit is not conveying material



1. Disconnect the flapper valve switch from the control box, by unscrewing the plastic retainer ring, and pulling the plug straight down.
2. Adjust the conveying time by pressing the up arrow button (the center LED on the display lights up). Convey time can be adjusted from 1 to 99 seconds, incrementally.
3. Make note of the conveying level and adjust time accordingly .

- Please Note: The material level inside the loader should never exceed the material inlet.

### Setting the line clearing time or purge time:

- It is only possible to set the purge time when the unit is not conveying material



1. Press and hold the "change-over" key, (bottom LED on the display lights up)



2. While holding the change-over key, adjust the purge time by pressing the up arrow. Purge time can be adjusted from 0 to 99 seconds.

- If no line clearing valve has been installed, be sure to set purging time to 0.

- Make note of the purge time and adjust for optimum efficiency

### Connecting the proportioning valve:

Control and power of the proportioning valve is supplied through a 4-wire control connection.

Brown	–	Pos. Power	X7, L
Blue	–	Neg. power	X7, N
Black	–	Line signal	X7, ZKW
Green/Yellow	–	–Ground	X3

3. Remove the control box face, and locate the removable plug in the bottom of the box.
4. Remove the plug and feed the wire of the proportioning valve through the empty hole.
5. Tighten the lock nut inside, position the wire length for optimum use and tighten the lock nut on the outside.
6. Strip the wires so that 1/4" of wire is showing, for connection to terminal blocks.
7. Remove the loader control face.

Upon removal of the loader control face you will see two printed circuit boards. One board on the reverse of the control face, and the other mounted inside the control box. The ground wire will connect to the terminal block X3 on the back of the control face. The other three wires connect to terminal block X7 inside the control box, in order from left to right Brown, Blue, then Black. Please refer to the schematic in the back of the manual.

### Connecting Material Lines:

Component 1 – connected to the intake port furthest from the air cylinder (regrind)

Component 2 – connected to the intake port closest to the air cylinder (virgin)

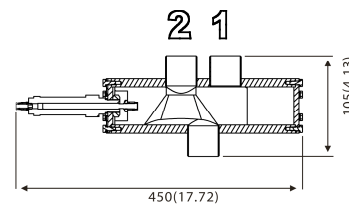

### Setting the ratio:

When the loader motor is not running, pressing the up arrow key will change the percentage of component 1. This can be set from 0% to 99%

### Set the cycle switching:

Press and hold the percentage key. Then by pressing the up arrow, you will be selecting the cycle time period in increments of 5 seconds.

Therefore, if the convey time is 60 seconds and you select a cycle time period of 10 seconds the valve will switch a total of 6 times.

